

Agilent Technologies

N5250A Network Analyzer Systems Installation Guide

Agilent Technologies

N5250A Network Analyzer Systems Installation Guide

Use this manual with the following documents:

PNA Series Network Analyzer Embedded Help System

PNA Series Network Analyzer Installation and Quick Start Guide
Part Number E8356-90001

PNA Series Network Analyzer CD-ROM
Part Number E8356-10001



Agilent Technologies

Manufacturing Part Number: Part Number: N5250-90001

Printed in USA: December 2003

Supersedes: October 17, 2003

© Copyright 2003 Agilent Technologies, Inc. All rights reserved.

Warranty Statement

THE MATERIAL CONTAINED IN THIS DOCUMENT IS PROVIDED “AS IS,” AND IS SUBJECT TO BEING CHANGED, WITHOUT NOTICE, IN FUTURE EDITIONS. FURTHER, TO THE MAXIMUM EXTENT PERMITTED BY APPLICABLE LAW, AGILENT DISCLAIMS ALL WARRANTIES, EITHER EXPRESS OR IMPLIED WITH REGARD TO THIS MANUAL AND ANY INFORMATION CONTAINED HEREIN, INCLUDING BUT NOT LIMITED TO THE IMPLIED WARRANTIES OF MERCHANTABILITY AND FITNESS FOR A PARTICULAR PURPOSE. AGILENT SHALL NOT BE LIABLE FOR ERRORS OR FOR INCIDENTAL OR CONSEQUENTIAL DAMAGES IN CONNECTION WITH THE FURNISHING, USE, OR PERFORMANCE OF THIS DOCUMENT OR ANY INFORMATION CONTAINED HEREIN. SHOULD AGILENT AND THE USER HAVE A SEPARATE WRITTEN AGREEMENT WITH WARRANTY TERMS COVERING THE MATERIAL IN THIS DOCUMENT THAT CONFLICT WITH THESE TERMS, THE WARRANTY TERMS IN THE SEPARATE AGREEMENT WILL CONTROL.

DFARS/Restricted Rights Notice

If software is for use in the performance of a U.S. Government prime contract or subcontract, Software is delivered and licensed as “Commercial computer software” as defined in DFAR 252.227-7014 (June 1995), or as a “commercial item” as defined in FAR 2.101(a) or as “Restricted computer software” as defined in FAR 52.227-19 (June 1987) or any equivalent agency regulation or contract clause. Use, duplication or disclosure of Software is subject to Agilent Technologies’ standard commercial license terms, and non-DOD Departments and Agencies of the U.S. Government will receive no greater than Restricted Rights as defined in FAR 52.227-19(c)(1-2) (June 1987). U.S. Government users will receive no greater than Limited Rights as defined in FAR 52.227-14 (June 1987) or DFAR 252.227-7015 (b)(2) (November 1995), as applicable in any technical data.

Safety Notes

The following safety notes are used throughout this document. Familiarize yourself with each of these notes and its meaning before performing any of the procedures in this document.

WARNING

Warning denotes a hazard. It calls attention to a procedure which, if not correctly performed or adhered to, could result in injury or loss of life. Do not proceed beyond a warning note until the indicated conditions are fully understood and met.

CAUTION

Caution denotes a hazard. It calls attention to a procedure that, if not correctly performed or adhered to, could result in damage to or destruction of the instrument. Do not proceed beyond a caution sign until the indicated conditions are fully understood and met.

Contents

1 Installing the System

Information in This Chapter	1-2
Chapter One at-a-Glance	1-2
N5250A Network Analyzer System.	1-3
What's Included.	1-4
Partial Systems	1-4
Site Preparation	1-5
Power Requirements.	1-5
Environmental Requirements	1-6
Space Requirements	1-7
Receiving the System	1-9
The System as Shipped.	1-9
Agilent Technologies Customer Engineering	1-9
System Contents	1-10
Basic System Configurations.	1-12
Coaxial Measurement.	1-12
Coaxial Measurement Configuration.	1-13
PNA, Controller, and Test Head Interconnections	1-14
Rear Panel Cabling.	1-14
Front Panel Cabling	1-15
Sequence of Test Head Connections.	1-17
System Cable Connections.	1-18
Millimeter-Head Controller	1-21
LED's	1-22
The Line Fuse	1-23
Available Fuses	1-23
Millimeter-Wave Test Heads	1-24
Connector Positions.	1-24
Power Supply Inputs.	1-24
Illustrations.	1-24
Operators Check.	1-26
Specifications	1-27
System Specifications (typical).	1-27
E8361A Option H11 Rear Panel Specifications.	1-29
N5250A Option 017 Test Head Bias-Tees Specifications	1-29
General E8361A Option H11 Specifications	1-29
System Performance Verification	1-30
When to Verify.	1-30
Materials Required	1-31
General Preparation	1-31
Verification Procedure.	1-32
Interpreting the Verification Results.	1-36
Improving the Verification Results	1-38

2 Safety and Regulatory Information

Information in This Chapter	2-2
Chapter Two at-a-Glance	2-2
Safety Symbols	2-3
General Safety Considerations	2-3
Safety Earth Ground	2-3
Before Applying Power	2-3
Servicing	2-4
Electrostatic Discharge Protection	2-5
Regulatory Information	2-6
Instrument Markings	2-6
Lithium Battery Disposal	2-6
Compliance with Canadian EMC Requirements	2-8
Compliance with German FTZ Emissions Requirements	2-8
Compliance with German Noise Requirements	2-8
Maintenance	2-9
Physical Maintenance	2-9
Electrical Maintenance	2-9
Replaceable Parts	2-10
Agilent Support, Services, and Assistance	2-12
Contacting Agilent	2-13
Service and Support Options	2-14
Shipping Your Analyzer to Agilent for Service or Repair	2-14

1 Installing the System

Information in This Chapter

This chapter provides installation and verification procedures that will help you set up and test your system.

Chapter One at-a-Glance

- N5250A Network Analyzer System
- Site Preparation
- Receiving the System
- Basic System Configurations
- PNA, Controller, and Test Head Interconnections
- System Cable Connections
- Millimeter-Head Controller
- Millimeter-Wave Test Heads
- Operators Check
- Specifications
- System Performance Verification

N5250A Network Analyzer System

The N5250A is a vector network analyzer system with an extremely wide frequency range of 10 MHz to 110 GHz. The N5250A uses the same 1.0 mm test port connections throughout its entire range of test frequencies. It is never necessary to make and break connections to complete a test.

The bias can be applied to a device under test (DUT) through the test ports using the bias-tees built into the PNA. Optionally, bias-tees can be added to the test heads closer to the test ports to improve the bias conditions of sensitive devices (Option 017).

The N5250A system can be used to make S-parameter measurements three different ways:

1. Continuous sweep 10 MHz to 110 GHz measurements utilizing 1.0 mm test ports on the test heads.
2. Standalone E8361A PNA measurements from 10 MHz to 67 GHz utilizing the PNA front panel 1.85 mm test ports. This is accomplished by disconnecting the controller and test heads from the PNA and restarting the PNA application.
3. Waveguide measurements from 67 GHz to 110 GHz utilizing the WR-10 waveguide flange on the waveguide T/R modules. This is accomplished by disconnecting the combiner assembly on the front of the test heads.

The illustration below shows the N5250A configured for coaxial measurement; the system can also be configured for on-wafer measurement using a wafer probe test station.

Figure 1-1 N5250A Network Analyzer System

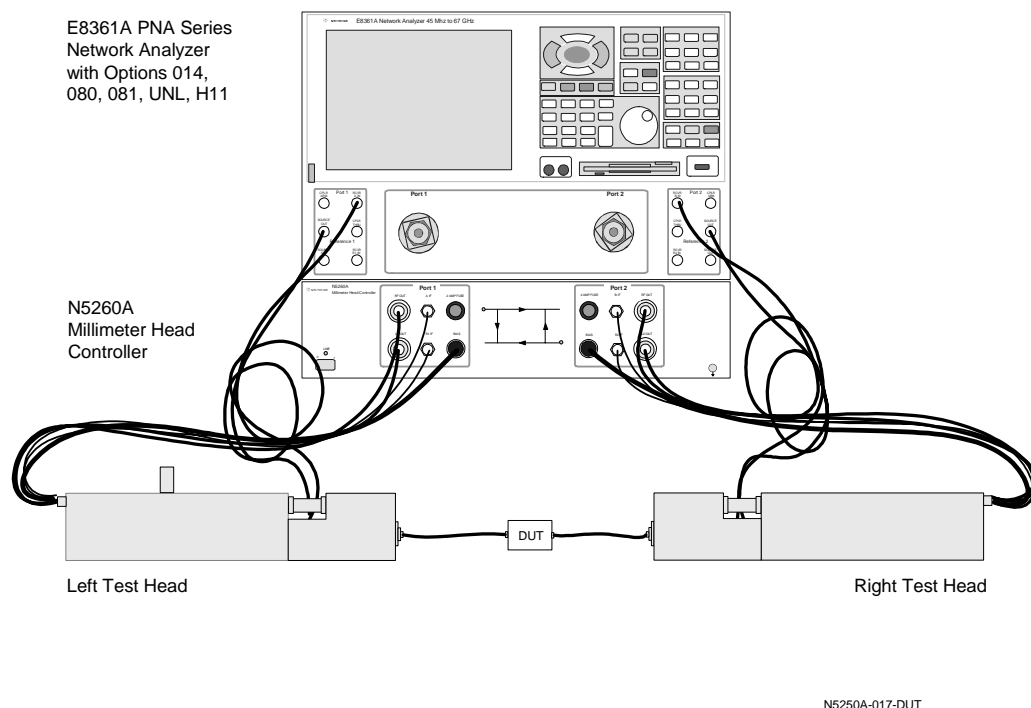

What's Included

See Table 1-4 on page 1-10 for a complete list of the components that are included with your system. The major components of the N5250A system are as follows:

- PNA Series Network Analyzer, E8361A with Option H11 (includes options UNL, 014, 080, and 081)
- N5260A Millimeter-Head Controller
- Millimeter-Wave Test Head Options:
 - N5250A-700 (standard) millimeter-wave test heads without bias-tees
 - N5250A-017 (option 017) millimeter-wave test heads with bias-tees

Partial Systems

Customers who already have the E8361A Network Analyzer with Option H11 can order the N5260A Millimeter-Head Controller, Millimeter-Wave Test Heads, and Cables to make a complete system.

- N5260A millimeter-head controller
- Millimeter-wave test head options:
 - N5260A-110 millimeter-wave test heads without bias-tees (N5250A Standard)
 - N5260A-120 millimeter-wave test heads with bias-tees (N5250A Option 017)

Site Preparation

Power Requirements

Before installing the system, be sure that the required ac power is available at all necessary locations.

- Three-wire power cables (which provide a safety ground) must be used with all instruments.
- Air-conditioning equipment (or other motor-operated equipment) should not be placed on the same ac line that powers the system.
- The table below lists the maximum VA ratings and BTU/hour ratings for all instruments in the system. This table can be used to determine both the electrical requirements and the air conditioning requirements of the system.

Table 1-1 Power Requirements of the System

Standard Equipment		
Instrument	Maximum VA Rating	Maximum BTU/hour
E8361A	350	1195
N5260A millimeter-head controller	320	1095
N5260-60007 left test head or N5260-60006 right test head	(powered from controller)	(powered from controller)
N5260-60011 left test head or N5260-60010 right test head	(powered from controller)	(powered from controller)
Total	670	2290

Note:

- (1) Values are based on 120 Vac supplied to each instrument at 60 Hz.
- (2) The millimeter-wave controller supplies power to the test heads.

Environmental Requirements

The environmental requirements of the system are listed in the table below. Note that these requirements are the same as those of the E8361A Network Analyzer with Option H11.

Table 1-2 Environmental Requirements

Temperature	
Operation	5 °C to 40 °C (41 °F to 104 °F)
Storage	-40 °C to +65 °C (-40 °F to +158 °F)
Measurement Calibration	20 °C to 26 °C (68 °F to 79 °F)
Performance Verification	Temperature must be within 1 °C (1.8 °F) of the temperature at which the measurement calibration was performed.
Relative Humidity	
Operation	5% to 95% at 40 °C or less (non-condensing)
Storage	5% to 95% at 65 °C or less (non-condensing)
Pressure Altitude (Operation or Storage)	Less than 4600 meters (~15,000 feet)

System Heating and Cooling

Install air conditioning and heating, if necessary, to maintain the ambient temperature within the appropriate range (as given in the table above). Air conditioning capacity must be consistent with the BTU ratings given in Table 1-1 on page 1-5.

Required Conditions for Accuracy Enhanced Measurement

Accuracy-enhanced (error-corrected) measurements require the ambient temperature of the N5250A to be maintained within ± 1 °C of the ambient temperature at calibration.

Space Requirements

Standard installation of the N5250A system includes configuration and installation of the system on a customer provided lab bench or table top of adequate size and strength.

System Weight and Dimensions

- 55 kg (110 lb)
- Required Bench Top Dimensions for the System:
 - Clearance above bench top: 43 cm (17 in)
 - Width: 127 cm (50 in)
 - Depth: 102 cm (40 in)

Component Weight and Dimensions

Table 1-3 shows the maximum weight and dimensions of the N5250A System components.

Table 1-3 N5250A System Components Weight and Dimensions

Test Head Model	Weight	Height	Width	Depth
Test Head (each)	3.4 kg (7.5 lb, ± 0.5 lb)	6.9 cm (2.7 in)	50.7 cm (20 in)	17.7 cm (6.9 in)
E8361A Opt H11 PNA	29 Kg (64 lb) nominal	26.7 cm (10.5 in)	42.5 cm (16.7 in)	42.6 cm (16.8 in)
N5260A Millimeter Head Controller	9.1 Kg (20 lb)	9.0 cm (3.5 in)	42.4 cm (16.75 in)	49.5 cm (19.5 in)

Figure 1-2 Test Head Dimensions for Mounting (left & right head are symmetrical)

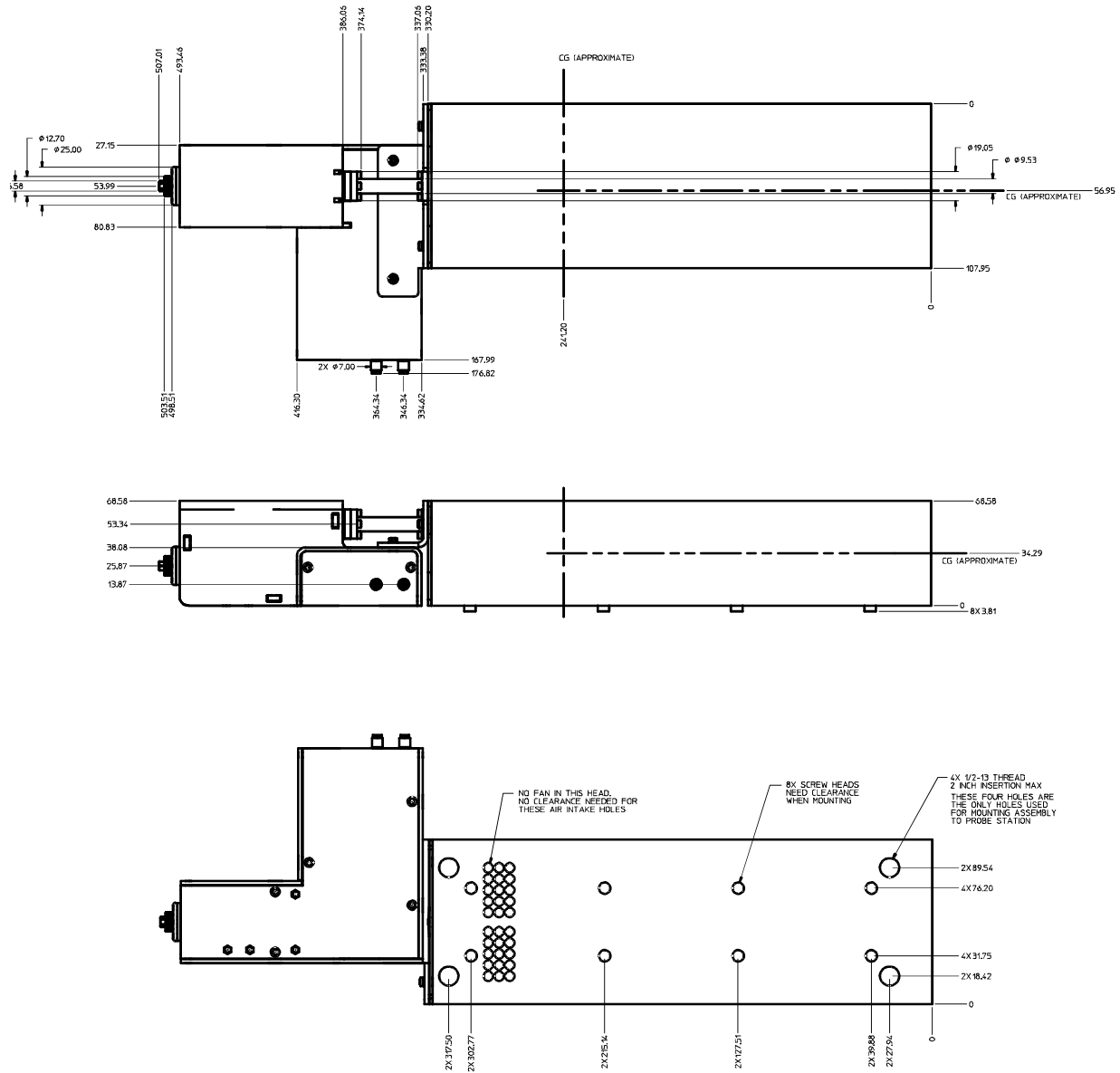

LEFT TEST HEAD (Port 1)
 Dimensions in mm

Receiving the System

WARNING **The millimeter-head controller and the test heads are sensitive to electrostatic discharge (ESD). Ground your work station before unpacking and installing the test heads. See Electrostatic Discharge Protection (on page 2-5).**

The System as Shipped

The N5250A system components will arrive packaged separately. For a complete list of components shipped with your system, refer to Table 1-4 on page 1-10.

When the entire shipment has arrived, contact Agilent Technologies to arrange for system installation, if installation is available in your area. See Agilent Support, Services, and Assistance (on page 2-12).

Keep the shipping containers until the system checklist has been completed, and the system has been checked mechanically and esoterically.

If the shipping container is damaged or the packaging material shows signs of stress, notify the carrier as well as the Agilent Technologies Customer Engineer. Keep the shipping materials for the carrier's inspection. Agilent Technologies will arrange for repair or replacement of damaged equipment without waiting for a claim settlement from the carrier. Refer to Agilent Support, Services, and Assistance (on page 2-12).

Agilent Technologies Customer Engineering

An Agilent Technologies Customer Engineer will be assigned to help you install the system. During installation, the Customer Engineer will do the following:

- Unpack the system components.
- Complete the system checklist, see Table 1-4 on page 1-10.
- Connect the PNA and the millimeter-head controller.
- Install the test heads.
- Run a performance verification of the system, which includes a measurement calibration.
- Provide user training for one engineer.

System Contents

Use the table below to verify that the shipment is complete. These are items that are supplied with all N5250A complete systems only.

Table 1-4 N5250A System Contents

✓	Agilent Part Number	Qty	Description
	N5250A-700 (Standard)	0 or 1	Vector Network Analyzer System, 10 MHz to 110 GHz, 1.0 mm (m) Test Ports
	Includes:		E8361A H11 PNA, N5260A Millimeter-Head Controller, Millimeter-Wave Test Heads (N5260A-110), and Cables
	N5250A-017 (Option 017)	0 or 1	Vector Network Analyzer System, 10 MHz to 110 GHz, 1.0 mm (m) Test Ports
	Includes:		E8361A H11 PNA, N5260A Millimeter-Head Controller, Millimeter-Wave Test Heads with Bias-tees (N5260A-120), and Cables
	E8361A H11 Includes:	1	PNA Series Microwave Vector Network Analyzer (10 MHz to 67 GHz)
	E8361A Option H11	1	IF Access
	E8361A Option 014	1	Configurable Test Set
	E8361A Option UNL	1	Source Attenuators and Bias-Tees
	E8361A Option 080	1	Frequency Offset
	E8361A Option 081	1	Reference Channel Switch
	E8356-10001	1	PNA Network Analyzer Manuals: E8361A Manual Set (CD)
	N5260A	1	Millimeter-Head Controller
	Includes:		
	85105-60030	2	Bias Cable
	85105-60033	4	IF Signal Cable
	8121-1221	4	RF and LO 3.5 mm Cable
	08503-60051	1	Test Set Interface Cable
	8120-1839	4	IF Signal Cable
	5061-9038	2	RF and LO SMA Cable
	1250-2604	4	SMA Right Angle Adapter (not required, use only if needed with 8121-1221 cables)

Table 1-4 N5250A System Contents

	5063-9226	1	Handle Set
	5063-9232	1	Rack Mount Flange Set
	N5250A-90001	1	Installation Guide
	N5260A-110 (Standard)	0 or 1	Millimeter-Wave Test Heads, 67 GHz to 110 GHz, 1 mm (m) Test Ports
	Includes:		
	N5260-60007 Includes:	1	Left Millimeter-Wave Test Head
	N5260-60002	1	Left Combiner Assembly
	N5260-60003	1	67 GHz to 110 GHz Wave Guide T/R Module with Attenuator (left)
	N5260-60006 Includes:	1	Right Millimeter-Wave Test Head
	N5260-60001	1	Right Combiner Assembly
	N5260-60004	1	67 GHz to 110 GHz Wave Guide T/R Module (right)
	N5260-60009	2	PNA Front Panel Test Port RF 1.85 mm (f)-(m) Cable
	8121-1233	2	PNA Front Panel Access Port RF 1.85 mm (m)-(m) Cable
	N5260A-120 (Option 017)	0 or 1	Millimeter-Wave Test Heads with Bas-Tees, 67 GHz to 110 GHz, 1mm (m) Test Ports
	Includes:		
	N5260-60011 Includes:	1	Left Millimeter-Wave Test Head with Bias-Tee
	N5260-60013	1	Left Combiner Assembly with Bias-tee
	N5260-60003	1	67 GHz to 110 GHz Wave Guide T/R Module with Attenuator (left)
	N5260-60010 Includes:	1	Right Millimeter-Wave Test Head with Bias-Tee
	N5260-60012	1	Right Combiner Assembly with Bias-tee
	N5260-60004	1	67 GHz to 110 GHz Wave Guide T/R Module (right)
	8121-1233	4	PNA Front Panel Access Port RF 1.85 mm (m)-(m) Cable

Basic System Configurations

The N5250A can be used in either of two basic configurations, depending on the means by which the test ports are connected to the device under test (DUT).

CAUTION Input power to the test ports must not exceed +27 dBm. Input power in excess of this level will damage expensive components. Observe proper precautions, especially when measuring amplifiers with gains of 20 dB or greater.

Coaxial Measurement

This configuration is used when the DUT has coaxial connectors. The N5250A test ports have 1.0 mm coaxial connectors, and are designed to cover a frequency range of 10 MHz to 110 GHz.

In this configuration, the test heads are placed on a work bench in front of the millimeter-head controller.

The DUT is normally connected to the test ports by way of a 1.0 mm coaxial cable (test port cable). Connect the device to Port 1 (left test head) directly, and to Port 2 (right test head) port by way of a test cable. It is also possible to connect the DUT using a test port cable on each test port, although this configuration will result in greater signal loss.

CAUTION Do not attempt to connect a test device directly between the two 1.0 mm test ports, without at least one test port cable. The test heads will not move freely enough to allow such a connection to be made safely.

Wafer Probe Measurement

This configuration is used for on-wafer testing; each test port is connected (through a 1.0 mm coaxial cable, or through an adapter and another type of coaxial cable) to a wafer test probe. Contact the manufacturer of the wafer probe station and an Agilent office for information on the cables and adapters needed to connect the test heads to the wafer probe station (refer to General Safety Considerations (on page 2-3).

In this configuration, the test heads are placed on X-Y positioners that are mounted to the wafer probe station.

NOTE The wafer probe measurement configuration is not documented in this manual.

For information about probing equipment and accessories, contact:

Cascade Microtech, Inc.
2430 NW 206th Avenue
Beaverton, Oregon 97006, USA
Toll-free telephone: (800) 550-3279

Telephone: (503) 601-1000
Fax: (503) 601-1002
Web site www.cascademicrotech.com
Email: sales@cmicro.com

Coaxial Measurement Configuration

Figure 1-3 shows how the instruments are configured on a work bench for the coaxial measurement configuration. The test heads are placed on the bench top in front of the PNA and controller.

Figure 1-3 Coaxial Measurement Configuration

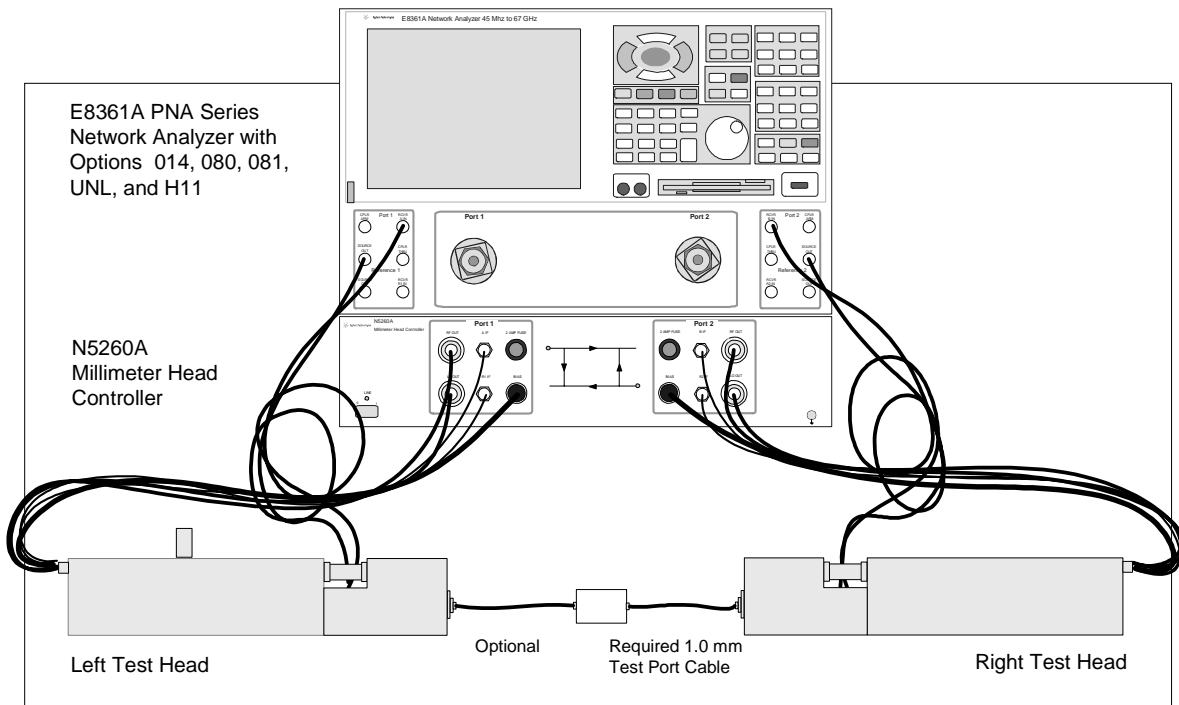

N5250A-017-WS-Config

PNA, Controller, and Test Head Interconnections

Rear Panel Cabling

Figure 1-4 shows the rear panel cabling. For cabling between the millimeter-wave controller and the test heads, see Front Panel Cabling (on page 1-15).

Figure 1-4 Rear View Cabling diagram

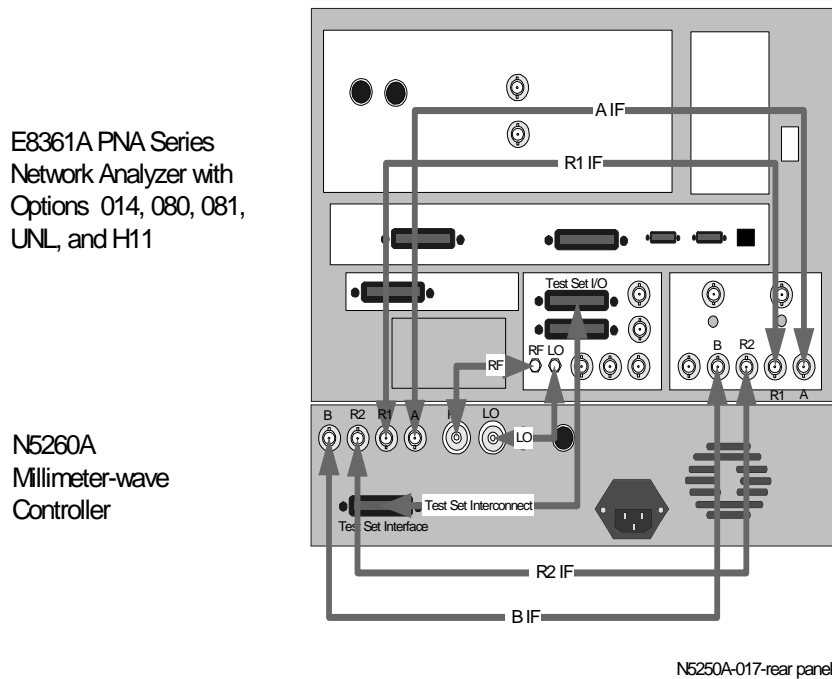

Front Panel Cabling

The interconnections between the controller and the test heads are shown in Figure 1-5.

NOTE The order in which cables are connected to a test head is significant; see Sequence of Test Head Connections (on page 1-17).

Figure 1-5 N5250A Option 017 Configuration

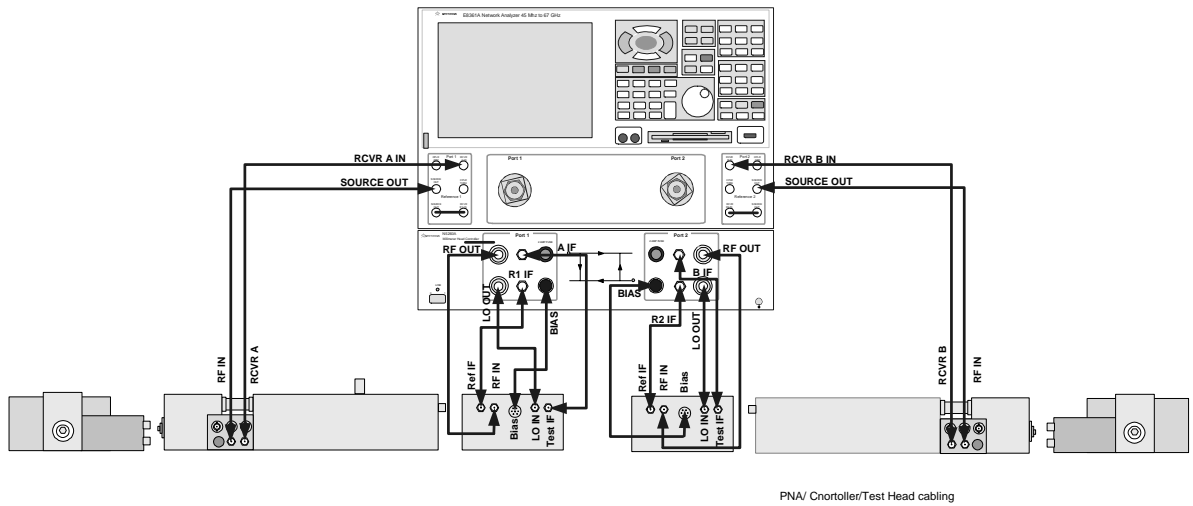

Figure 1-6 N5250A Standard Configuration

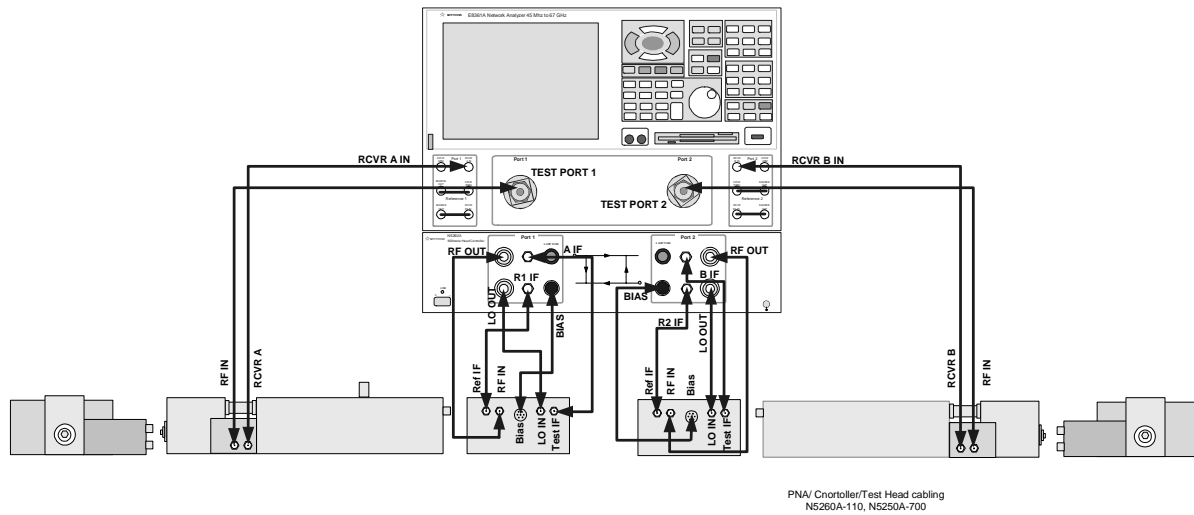
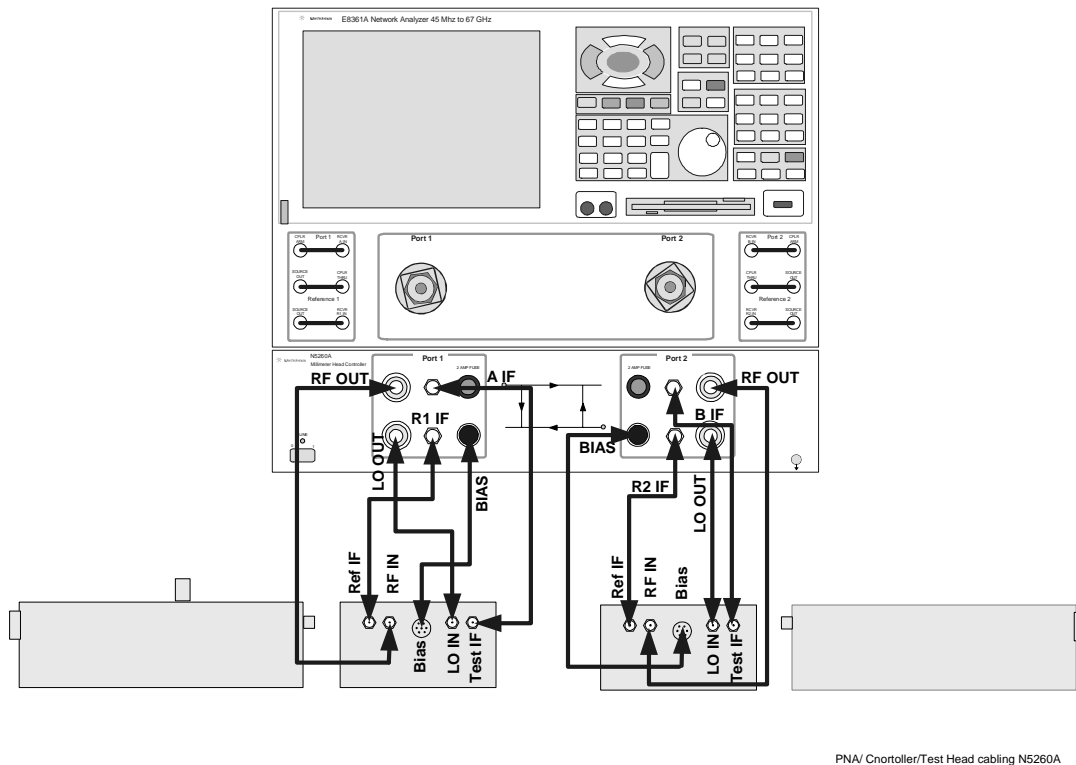

Figure 1-7 N5250A Waveguide Test Port Configuration with Combiner Assemblies Removed (Banded Solution for N5260A)



Sequence of Test Head Connections

NOTE Use a 57 N-cm (5 in-lb) torque wrench to tighten the SMA connectors and a 90 N-cm (8 in-lb) torque wrench to tighten the 1.85 mm and 3.5 mm connectors.

The connectors on the backs of the test heads are very closely spaced. Attaching cables to these connectors is easiest if they are attached in the following sequence as illustrated in Figure 1-8.

1. BIAS (+12 V)
2. RF INPUT; SMA connector
3. LO INPUT; SMA connector
4. Ref IF; SMA connector
5. Test IF; SMA connector
6. RCVR A or B; 1.85 mm connector
7. RF IN (Port 1 or 2); 1.85 mm connector
8. Ground unit (GNDU); mini-triaxial connector (N5250A Option 017)
9. Sense; mini-triaxial connector (N5250A Option 017)
10. Force; mini-triaxial connector (N5250A Option 017)

Figure 1-8 Test Head Cabling Sequence

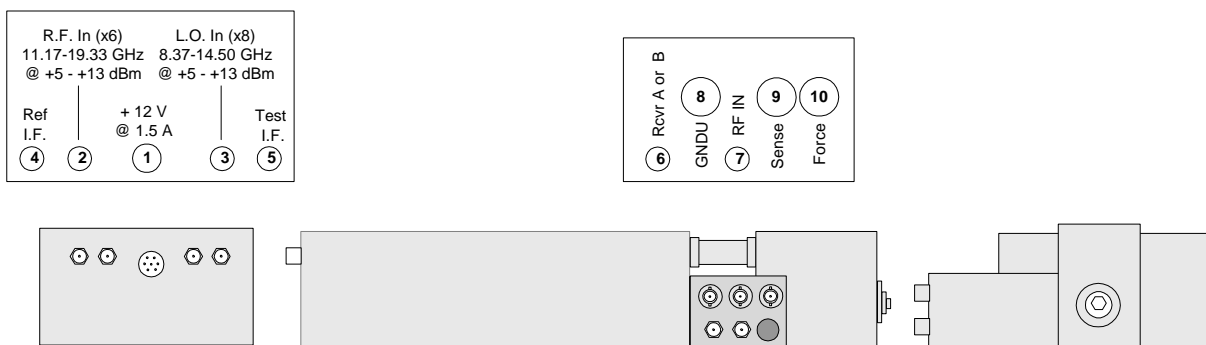

Test Head Sequence

System Cable Connections

In this table, a complete from/to connection list is given for the network analyzer: the RF, LO, controller, left test head, and the right test head. In other words, each cable is listed twice, and can be found by looking up the connection from either end. The duplicate listings make it easier to check the cabling after installation, if a cabling error is suspected.

Table 1-5 N5250A Cable List and Connections

From E8361A H11:	To:	Cable Type	Part Number
Rear Panel:			
8.333 MHz IF Input A	N5260A--IF Output A	BNC	8120-1839
8.333 MHz IF Input R1	N5260A--IF Output R1	BNC	8120-1839
8.333 MHz IF Input R2	N5260A--IF Output R2	BNC	8120-1839
8.333 MHz IF Input B	N5260A--IF Output B	BNC	8120-1839
Test Set Drivers RF	N5260A--RF Drive	SMA	5061-9038
Test Set Drivers LO	N5260A--LO Drive	SMA	5061-9038
Test Set I/O	N5260A--Test Set Interface	Multi pin	08503-60051
Front Panel:			
Rcvr A	Rcvr A N5260-60001 <i>or</i> N5260-60013	1.85 mm	8121-1233
Rcvr B	Rcvr B N5260-60002 <i>or</i> N5260-60012	1.85 mm	8121-1233
Test Port 1 (N5250A Standard)	N5260-60002--RF In	1.85 mm	N5260-60009
Test Port 2 (N5250A Standard)	N5260-60001--RF In	1.85 mm	N5260-60009
Source Out 1 (N5250A Option 017)	N5260-60013--RF In	1.85 mm	8121-1233
Source Out 2 (N5250A Option 017)	N5260-60012--RF In	1.85 mm	8121-1233
From N5260A Millimeter-Head Controller:	To:	Cable Type	Part Number
Front Panel:			
Bias (Port 1)	Bias (+12 V) N5260-60003	Multi pin	85105-60030
A IF (Port 1)	Test IF N5260-60003	SMA	85105-60033
R1 IF (Port 1)	Ref IF N5260-60003	SMA	85105-60033
RF Out (Port 1)	RF In N5260-60003	3.5 mm	8121-1221

Table 1-5 N5250A Cable List and Connections

LO Out (Port 1)	LO In N5260-60003	3.5 mm	8121-1221
Bias (Port 2)	Bias (+12 V) N5260-60004	Multi pin	85105-60030
R2 IF (Port 2)	Ref IF N5260-60004	SMA	85105-60033
B IF (Port 2)	Test IF N5260-60004	SMA	85105-60033
RF Out (Port 2)	RF In N5260-60004	3.5 mm	8121-1221
LO Out (Port 2)	LO In N5260-60004	3.5 mm	8121-1221
Rear Panel:			
IF Output A	8.333 MHz IF Input A E8361A	BNC	8120-1839
IF Output R1	8.333 MHz IF Input R1 E8361A	BNC	8120-1839
IF Output R2	8.333 MHz IF Input R2 E8361A	BNC	8120-1839
IF Output B	8.333 MHz IF Input B E8361A	BNC	8120-1839
RF Drive	Test Set Drivers RF E8361A	SMA	5061-9038
LO Drive	Test Set Drivers LO E8361A	SMA	5061-9038
Test Set Interface	Test Set I/O E8361A	Multi pin	08503-60051
From Right Millimeter-Wave Test Head:	To:	Cable Type	Part Number
Bias (+12 V) N5260-60004	Bias N5260A	Multi pin	85105-60030
Test IF N5260-60004	A IF N5260A	SMA	85105-60033
Ref IF N5260-60004	R1 IF N5260A	SMA	85105-60033
RF In N5260-60004	RF Out N5260A	3.5 mm	8121-1221
LO In N5260-60004	LO Out N5260A	3.5 mm	8121-1221

Table 1-5 N5250A Cable List and Connections

RF In N5260-60001 (N5250A Standard)	Test Port 2 E8361A	1.85 mm	N5260-60009
RF In N5260-60012 (N5250A Option 017)	Source Out 2 E8361A	1.85 mm	8121-1233
Revr B N5260-60001 <i>or</i> N5260-60012	Revr B E8361A	1.85 mm	8121-1233
From Left Millimeter Module:	To:	Cable Type	Part Number
LO In N5260-60003	LO Out	3.5 mm	8121-1221
RF IF N5260-60003	RF Out	3.5 mm	8121-1221
Ref IF N5260-60003	R2 IF	SMA	85105-60033
Test IF N5260-60003	B IF	SMA	85105-60033
Bias (+12 V) N5260-60003	Bias	Multi pin	85105-60030
RF In N5260-60002 (N5250A Standard)	Test Port 1 E8361A	1.85 mm	N5260-60009
RF In N5260-60013 (N5250A Option 017)	Source Out 1 E8361A	1.85 mm	8121-1233
Revr A N5260-60002 <i>or</i> N5260-60013	Revr A E8361A	1.85 mm	8121-1233

Millimeter-Head Controller

The front panel of the millimeter-head controller is illustrated below.

Figure 1-9 Front Panel (Millimeter-Head Controller)

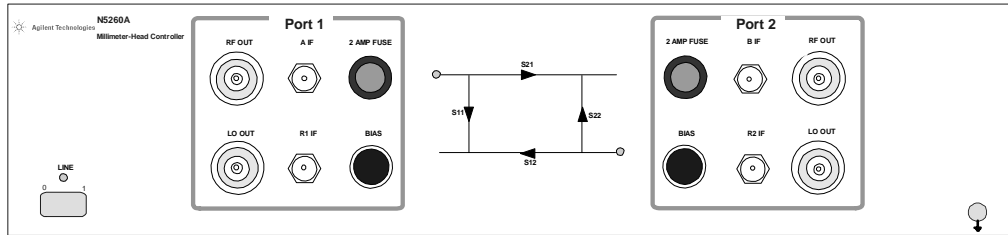

N5260A-TS-Front Panel

LED's

Three LEDs are used as indicators on the front panel.

Line	Lights to indicate that line power to the controller is ON .
S21, S11	This LED, located at the upper left of the S-parameter diagram, is lit when the RF source is switched to Port 1.
S12, S22	This LED, located at the lower right of the S-parameter diagram, is lit when the RF source is switched to Port 2.

Connectors (Port 1)

RF OUT	This 3.5 mm connector provides the left test head with the RF signal.
LO OUT	This 3.5 mm connector provides the left test head with the LO signal.
A IF	This SMA (f) connector receives, from the left test head, the "A" IF input.
R1 IF	This SMA (f) connector receives, from the left test head, the "R1" IF input.
BIAS	This multi-pin connector provides power supply voltages to the left test head.

Connectors (Port 2)

RF OUT	This 3.5 mm connector provides the right test head with the RF signal.
LO OUT	This 3.5 mm connector provides the right test head with the LO signal.
B IF	This SMA (f) connector receives, from the right test head, the "B" IF input.
R2 IF	This SMA (f) connector receives, from the right test head, the "R2" IF input.
BIAS	This multi-pin connector provides power supply voltages to the right test head.
Fuse	The fuse is located inside the line module on the rear panel of the millimeter-wave controller, as shown in Figure 1-10. For 110 V operation, the fuse rating should be 3 A; for 220 V operation, it should be 3 A (or 3.15 A). Review the information on the right of the drawing to replace the line fuse or to set the voltage selector cam.

WARNING For continued protection against fire hazard, replace the line fuse only with the same type and rating. The use of other fuses or materials is prohibited.

The Line Fuse

The line fuse, as well as a spare, reside within the line module. Figure 1-10 illustrates where the fuses are and how to access them.

Available Fuses

United States (115 V orientation)

Fuse (F 3 A/250V, 2110-0780) U.L. listed and CSA certified

Europe (230 V orientation)

Fuse (F 3.15 A/250V, 2110-0655) IEC certified and U.L. recognized

Figure 1-10 Location of Line Fuses

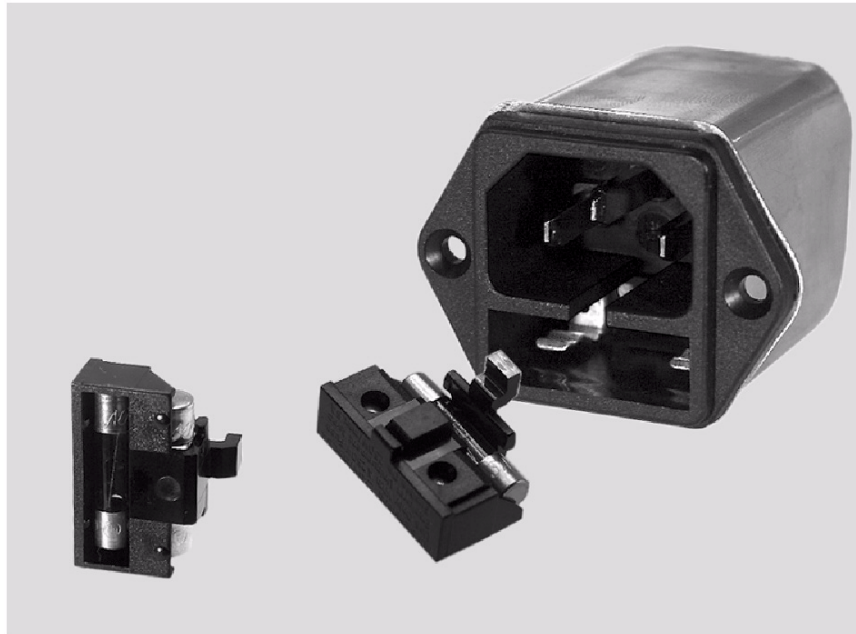

Millimeter-Wave Test Heads

Port 1 and Port 2 are in the left and right test heads, respectively. The test heads are placed on the work surface in front of the PNA and controller.

Connector Positions

The test heads are symmetrical with regard to the positions of the test port connectors. When the test heads are placed side by side, facing each other, the Port 1 connector faces the Port 2 connector.

It is usually best to position the right test head across from the left test head, so that the test ports are in line. This reduces strain on test cables.

Power Supply Inputs

The test heads do not have their own power supplies; each head receives dc power from the millimeter-head controller, by way of a multi-pin interface cable.

Illustrations

The left and right test heads are illustrated in Figure 1-11. They consist of a combiner assembly and a wave guide module. The combiner assembly contains a coupler and combiner, and optionally contains a bias-tee (Option 017). The multiple-connector panels provide connections between the test head, controller, and the PNA. Refer to Figure 1-5 through Figure 1-7.

Figure 1-11 Left and Right Millimeter-Wave Test Heads

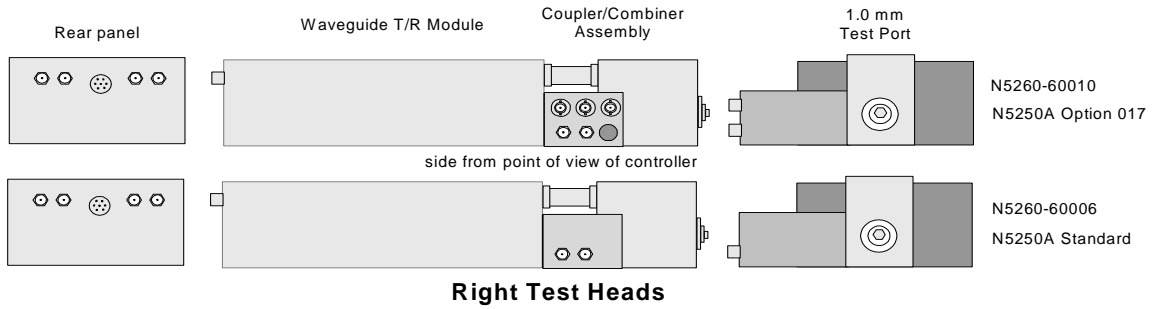
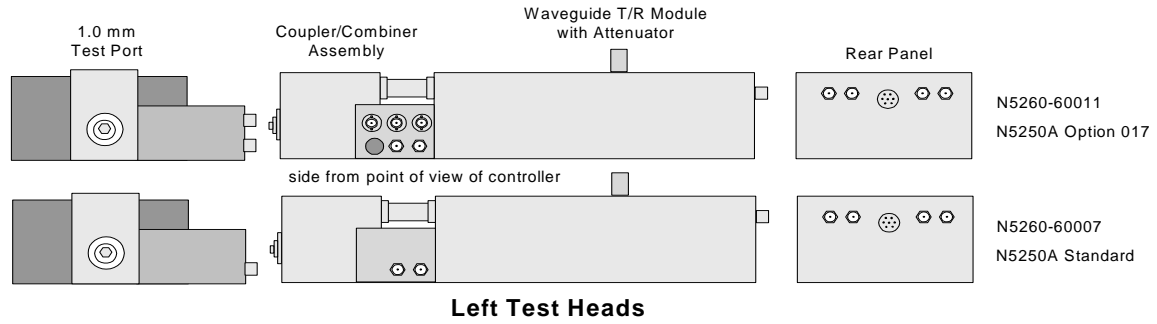

Operators Check

1. Connect a 1.0 mm short to Port 1 and Port 2.
2. Restart the PNA application and perform a factory preset.
3. On the PNA menu bar select: **System > Service > Utilities > Receiver Display**.
4. Set the IF bandwidth to 1 kHz.

The traces on the display should be similar to the example traces shown in Figure 1-12. If there are power holes, examine the system for loose or damaged cables, dirty or damaged connectors, proper connector torque etc.

Figure 1-12 Typical Receiver Display

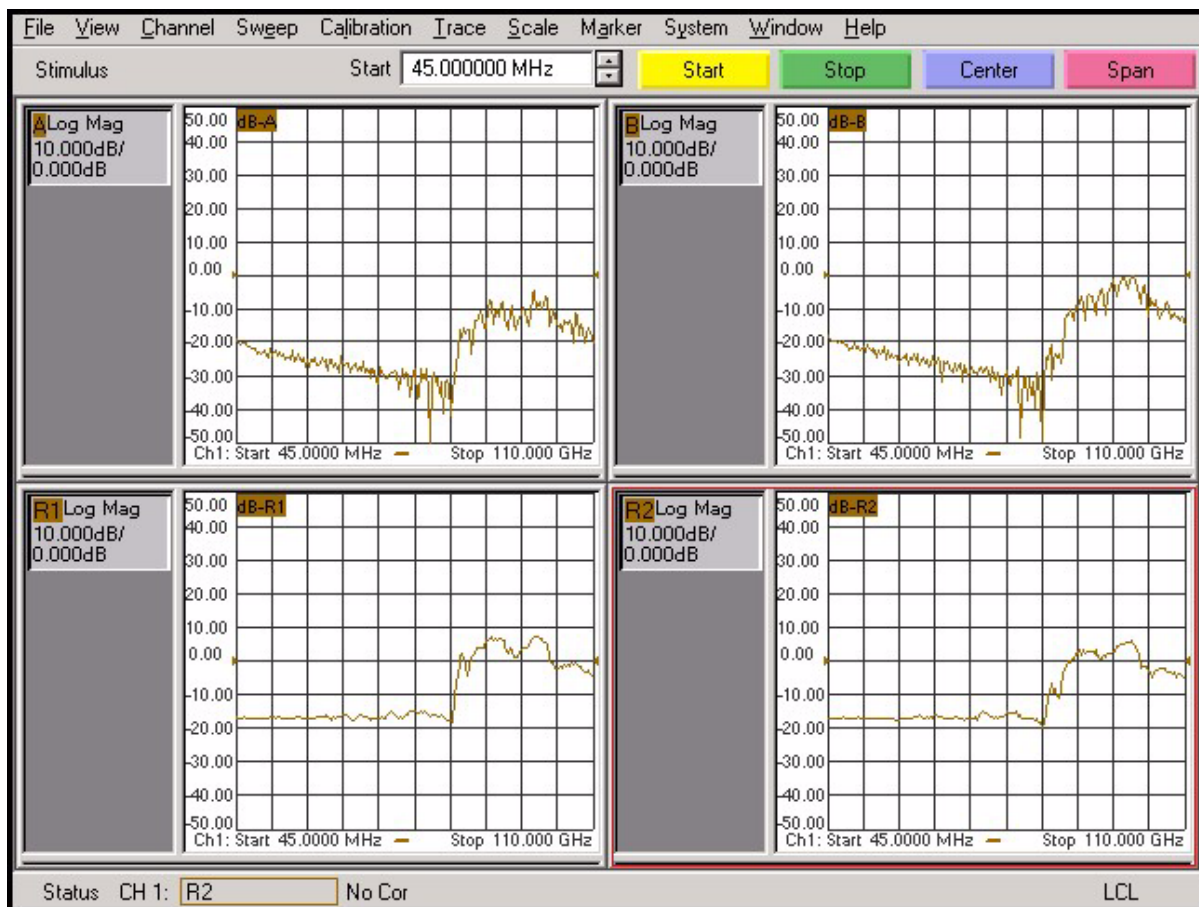

Specifications

System Specifications (*typical*)

The N5250A system has typical (non-warranted) specifications only, see Table 1-6.

Table 1-6 Typical System Specifications

Test Port Power (dBm)	1.0 mm Test Port (Std. Configuration ¹ or Opt 017) ²	1.85 mm PNA Port	WR-10 Waveguide Port
10 MHz to 45 MHz	-8	-7	
45 MHz to 500 MHz	-3	-1	
500 MHz to 2 GHz	0	+2	
2 GHz to 10 GHz	-2	+2	
10 GHz to 24 GHz	-5	0	
24 GHz to 30 GHz	-7	0	
30 GHz to 40 GHz	-10	-1	
40 GHz to 45 GHz	-15	-5	
45 GHz to 50 GHz	-12	-1	
50 GHz to 60 GHz	-17	-4	
60 GHz to 67 GHz	-22	-8	
67 GHz to 70 GHz	-9		-2
70 GHz to 75 GHz	-7		0
75 GHz to 80 GHz	-6		+1
80 GHz to 100 GHz	-5		+1
100 GHz to 110 GHz	-8		-2
Noise Floor (dBm)	1.0 mm Test Port	1.85 mm PNA Port	Waveguide Port
10 MHz to 45 MHz	-71	-72	
45 MHz to 500 MHz	-97	-98	
500 MHz to 2 GHz	-120	-121	
2 GHz to 10 GHz	-118	-121	
10 GHz to 24 GHz	-116	-121	
24 GHz to 30 GHz	-107	-112	
30 GHz to 40 GHz	-102	-108	
40 GHz to 45 GHz	-99	-106	

Table 1-6 Typical System Specifications

45 GHz to 50 GHz	-97	-104	
50 GHz to 60 GHz	-97	-104	
60 GHz to 67 GHz	-92	-103	
67 GHz to 70 GHz	-77		-84
70 GHz to 75 GHz	-81		-87
75 GHz to 80 GHz	-91		-97
80 GHz to 100 GHz	-94		-100
100 GHz to 110 GHz	-95		-100
System Dynamic Range (dB)	1.0 mm Test Port	1.85 mm PNA Port	Waveguide Port
10 MHz to 45 MHz	63	65	
45 MHz to 500 MHz	94	97	
500 MHz to 2 GHz	120	123	
2 GHz to 10 GHz	116	123	
10 GHz to 24 GHz	111	121	
24 GHz to 30 GHz	100	112	
30 GHz to 40 GHz	92	107	
40 GHz to 45 GHz	84	101	
45 GHz to 50 GHz	85	103	
50 GHz to 60 GHz	80	100	
60 GHz to 67 GHz	75	95	
67 GHz to 70 GHz	68		82
70 GHz to 75 GHz	74		87
75 GHz to 80 GHz	85		98
80 GHz to 100 GHz	89		101
100 GHz to 110 GHz	87		98
Test Port Damage Level (dBm)	1.0 mm Test Port	1.85 mm PNA Port	Waveguide Port
10 MHz to 110 GHz	+27	+27	+27

1. Assumes a 30 inch cable from the PNA 1.85 mm Test Port Out is used to provide the 10 MHz to 67 GHz source signal. The standard configuration does not have a bias-tee in the 1.0 mm test head and uses this connection.
2. Assumes a 30 inch cable from the PNA Source Out bulkhead connector is used to provide the 10 MHz to 67 GHz source signal. The Option 017 configuration includes a bias-tee in the 1.0 mm test head and uses this connection.

E8361A Option H11 Rear Panel Specifications

Table 1-7 General E8361A H11 Rear Panel Specifications

IF Connectors:	A, R1, R2, B
IF Connector Input Frequency:	8.333 MHz
Damage Level to IF Connector Inputs:	-20.0 dBm
0.1 dB Compression Point:	-27.0 dBm
Pulse Input Connectors:	A, R1, R2, B
Drive Voltage:	TTL (0, +5.0) Volts

N5250A Option 017 Test Head Bias-Tees Specifications

Table 1-8 Test Head Bias Input Connector

GNDU:	Mini-Triaxial Connector
Sense:	Mini-Triaxial Connector
Force:	Mini-Triaxial Connector
Maximum Voltage:	± 30 VDC (typical)
Damage Voltage:	± 40 VDC
Maximum Current:	± 0.5 AMP

NOTE Pulse input connectors are non-operational without Pulse Measurement Capability (Option H08) enabled.

General E8361A Option H11 Specifications

NOTE The E8361A Option H11 specifications are identical to the specifications given for the E8361A Option UNL, 080, 081, and 014 in the E8361A data sheet.

System Performance Verification

NOTE Since the N5250A has typical (non-warranted) specifications only, the SYSTEM PERFORMANCE VERIFICATION is not a PASS/FAIL test. The SYSTEM PERFORMANCE VERIFICATION is a test to establish BASELINE PERFORMANCE after the installation.

The system verification procedure is automated by the analyzer firmware. For each verification device, the analyzer reads a file from the verification disk and sequentially measures the magnitude and phase for all four S-parameters.

System verification is performed at the N5250A system 1.0 mm port connectors over a frequency range of 45 MHz to 110 GHz with an Agilent 85059A 1.0 mm calibration and verification kit.

For system verification to perform correctly, it is NECESSARY that the verification devices be measured with their female connectors connected to Port 1 and their male connectors connected to Port 2.

The following procedure, and the connection prompts given, use the 11500-60001 (11500I) 1.0 mm female-to-female cable connected to Port 2. This cable is included in the 85059A 1.0 mm calibration and verification kit.

When to Verify

After installation of the system is complete, a performance verification is necessary to assure proper system operation. This initial verification is included with the installation.

After the initial verification, the verification should be repeated once a year. This recommended interval assumes that Agilent cables are used with the system.

If non-Agilent cables, adaptors, or other fixtures are used, the verification schedule must be determined by the user, as the characteristics of these devices are unknown. In establishing a verification schedule, the following factors should be considered:

- Frequency of use
- Amount of cable movement
- Amount of drift occurring between prior verifications

NOTE Performance verification of a system performed at long intervals is *not* to be confused with measurement calibration. Measurement calibration typically is performed on a daily basis, or when the measurement setup or conditions have changed.

Materials Required

The following materials are required to run the tests:

- N5250A system (including system cables)
- 85059A 1.0 mm Precision Calibration and Verification Kit

General Preparation

Prepare for performance verification by completing the following procedure:

1. Measure the environment temperature and humidity. The temperature must be between +20 °C and +26 °C. Additionally, the temperature cannot vary by more than ± 1 °C after calibration.
2. Perform a good installation checkout on the N5250A system.
3. Power on the system components in the following order:
 - a. N5260A Millimeter-head controller
 - b. E8361A Option H11 PNA
4. Remember to allow at least one hour for warm up and temperature stabilization of the components. The temperature of the calibration and verification kit must be stable with the environment temperature.
5. If you desire printed test outputs, connect a printer to the analyzer. For the printer, ensure that the correct driver is loaded and the printer is defined as the default printer. Refer to the embedded help in the analyzer for printer setup.

Verification Procedure

Figure 1-13 System Verification Dialog Box

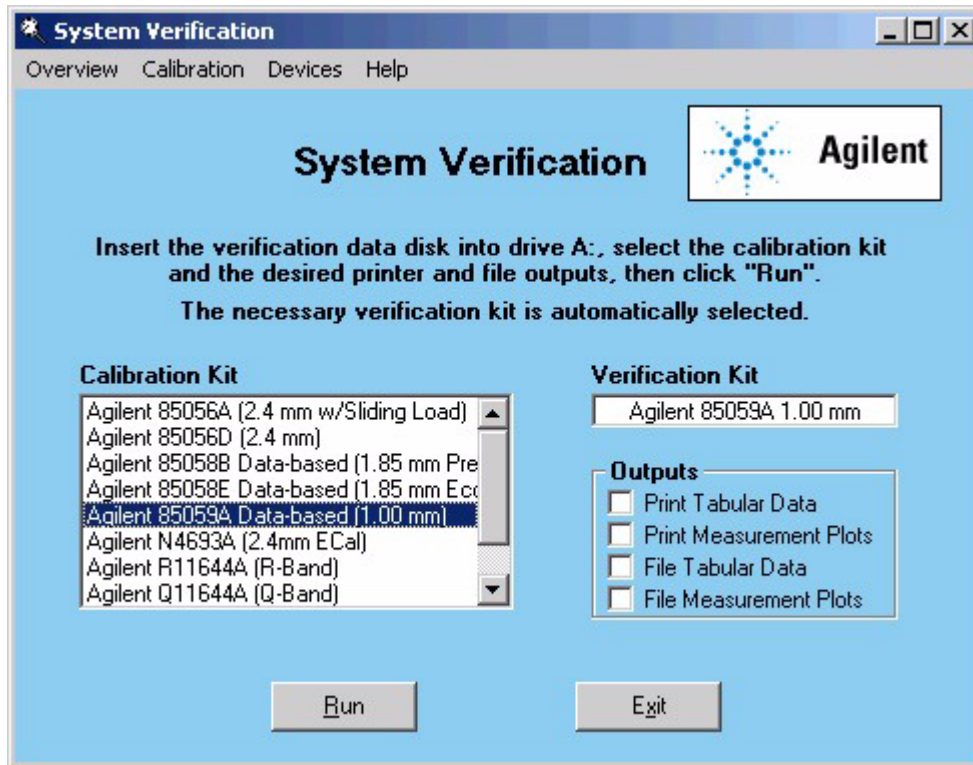

1. Insert the verification kit data disk into the analyzer disk drive.
2. On the **System** menu, point to **Service**, and then click **System Verification**. The **System Verification** dialog box is displayed; refer to Figure 1-13.

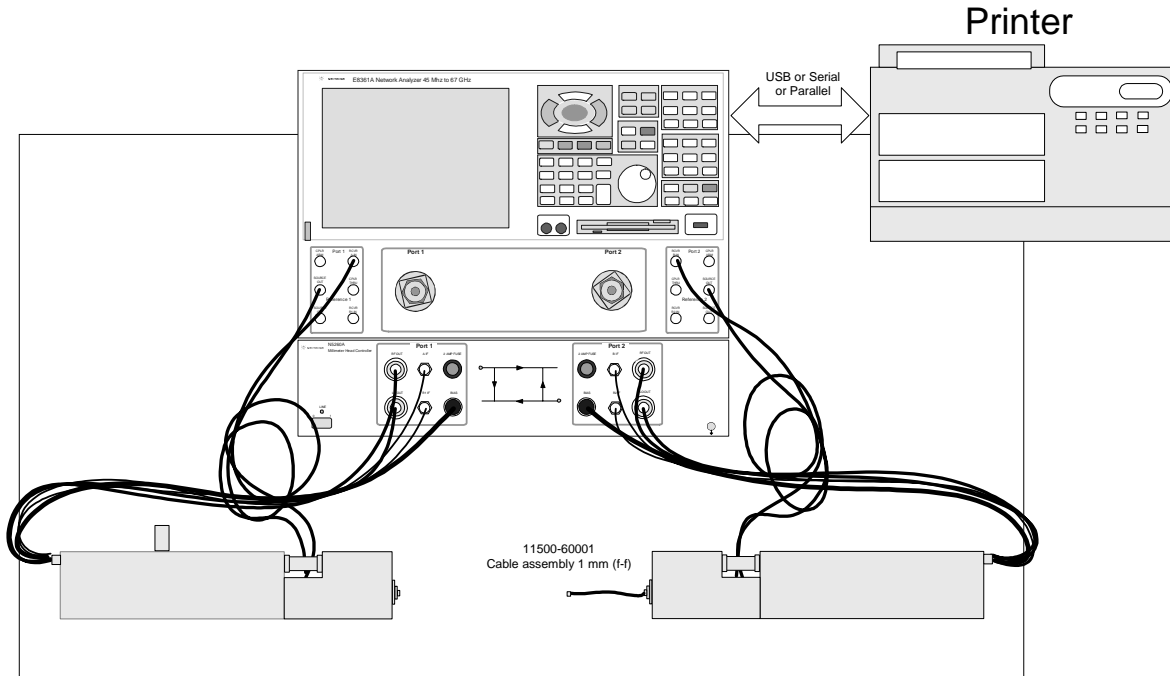
Figure 1-14 System Verification Connections

N5250A-017-WS-Config

3. In the **Calibration Kit** box, select the “Agilent 85059A Data-based (1.00 mm)” calibration kit by clicking on it. The corresponding verification kit to use is selected for you and displayed in the **Verification Kit** box. Refer to Figure 1-13.
4. Under **Outputs**, select from the following options to print the results or save the results to a file. Refer to Figure 1-13.
 - **No Selection:** No printout or file of results.
 - **Tabular Data:** Print or file the verification data in tabular form which includes measured data. For an example, refer to Figure 1-16 on page 1-36.
 - **Measurement Plots:** Print or file the verification data in graphical form. The graphical form includes the measured data trace and factory supplied data trace. For an example, refer to Figure 1-17 on page 1-37.
 - **Selection of Both:** Print or file the verification data in both formats.

System Performance Verification

NOTE For printed output, it is assumed that the printer has been tested and the Windows 2000 driver is installed for the printer that is being used. The system verification test prints to the printer that has been designated as the default printer. (On the Windows Desktop display, click on **My Computer**, **Control Panel**, and then **Printers** to verify the printer setup.)

5. Click **Run**.

6. Install the 1.0 mm female to female cable (8.8 cm, Agilent part number 11500-60001) onto the right test head (port 2) prior to calibration as shown in Figure 1-14. This cable is part of the 85059A 1.0 mm Precision Calibration and Verification Kit and is considered to be a test port cable.

CAUTION Do not remove this test port cable once the Calibration/Verification process has begun. If the test port cable becomes loose or is removed during the calibration/verification process, the calibration is invalid.

CAUTION Do not pull on the connectors on the ends of the test port cable —this will damage the cable. Avoid damaging the cable once it is connected to port 2 by carefully making the thru connection between the two test heads. This is best done by placing the two test heads on a smooth surface and gently sliding the right test head (port 2) towards the left test head (port 1).

7. Follow the instructions on the analyzer for performing a full 2-port calibration. The parameters for the calibration are setup automatically by the program.
8. At the last step of the calibration sequence it is necessary to make a thru connection. To make the thru connection, gently slide the right test (port 2) towards the left test head (port 1) a little bit at a time, while turning the threaded ring on the left head test port connector by hand onto the cable attached to the right test head. Do not use the threaded ring on the test port connector to pull the cable into the connector. Repeat this process until the cable is firmly seated into port 1, then make the threaded ring barely finger tight. Finally use the torque wrench on the port 1 threaded ring and a backup wrench on the cable to tighten the connection.
9. After completion of the full 2-port calibration, follow the instructions on the analyzer for performing the system verification. Use the match thru and mismatch thru verification standards provided with the 85059A 1.0 mm Precision Calibration and Verification kit. Insert the devices as shown in Figure 1-15.

NOTE It is recommended to connect the Verification Standards to the test port cable on port 2 prior to attempting to connect to port 1. Then follow the recommended procedure for making a thru connection outlined under Step 8 above to avoid damaging the cable.

Figure 1-15 System Verification Device Connections

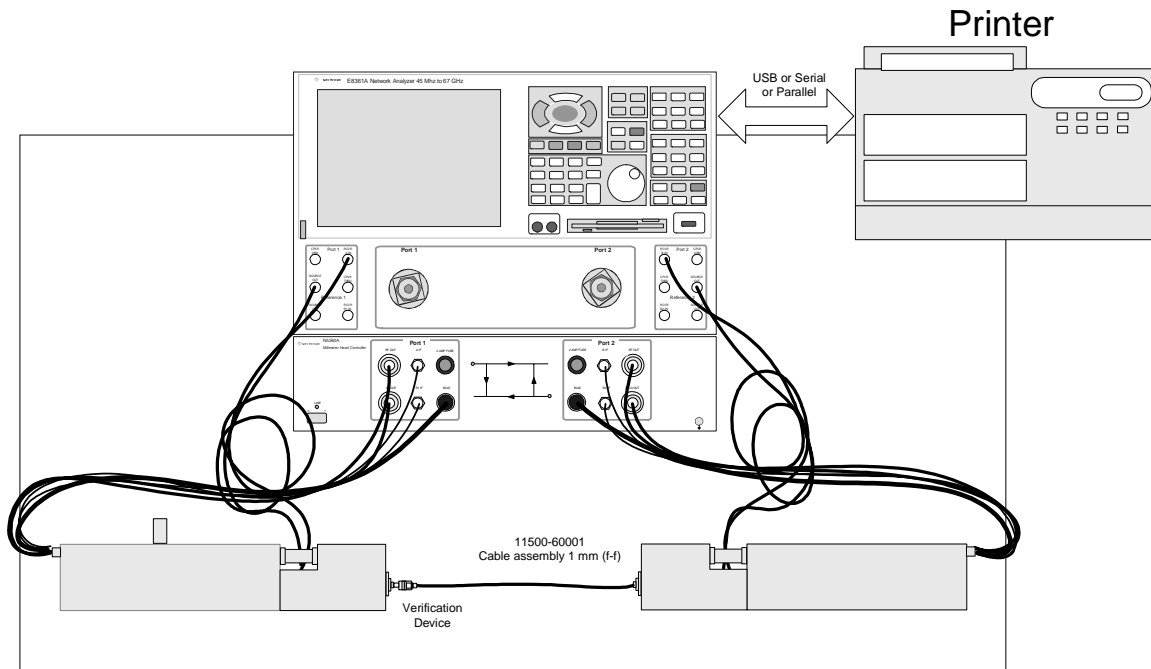

N5250A-017-WS-Config

Interpreting the Verification Results

Figure 1-16 shows an example of typical verification results with **Tabular Data** selected in the **Outputs** area of the **System Verification** dialog box.

At the top of the printed output is the name of the device, the serial number of the device, and the date tested.

Each S-parameter measurement result is printed with the frequency tested, the factory data, and the measured data.

Figure 1-16 Example of Printed Tabular Verification Results

Sys Ver -- Match Thru magnitude results, Serial #00378 -- 10/2/2003 4:26:34 PM
Instrument Tested: E8361A 014 & UNL US43140014

S11 Results

Freq. (MHz)	S11 Factory Data (lin)	S11 Measured (lin)
45	.001	.001
2500	.007	.005
5000	.016	.006
7500	.01	.013
10000	.011	.013
12500	.01	.007
15000	.007	.005
17500	.016	.017
20000	.019	.023
22250	.025	.016
22500	.026	.016
25000	.016	.008
27500	.006	.027
30000	.014	.036
32500	.018	.03
35000	.02	.012
37500	.023	.022
40000	.014	.042
42500	.008	.036
44500	.008	.025
45000	.009	.016
47500	.021	.013
50000	.022	.023
52500	.021	.026
55000	.023	.008
57500	.02	.013
60000	.007	.019
62500	.022	.017
65000	.044	.006
66750	.054	.021
67500	.056	.027
70000	.054	.033
72500	.035	.028
75000	.006	.02
77500	.036	.017
80000	.051	.038
82500	.051	.037
85000	.043	.027
87500	.025	.034
89500	.012	.036
90000	.01	.034
92500	.033	.024
95000	.063	.027
97500	.078	.049
100000	.082	.059
102500	.057	.037
105000	.009	.018
107500	.042	.054
110000	.079	.081

Figure 1-17 shows an example of typical verification results with **Measurement Plots** selected in the **Outputs** area of the **System Verification** dialog box. The screen shot graphical results show the following:

- the name of the device measured
- the serial number of the device
- the parameters measured
- Results of the measurements.
- Data measured at the factory from the verification kit.

Figure 1-17 Example of Printed Graphical Verification Results

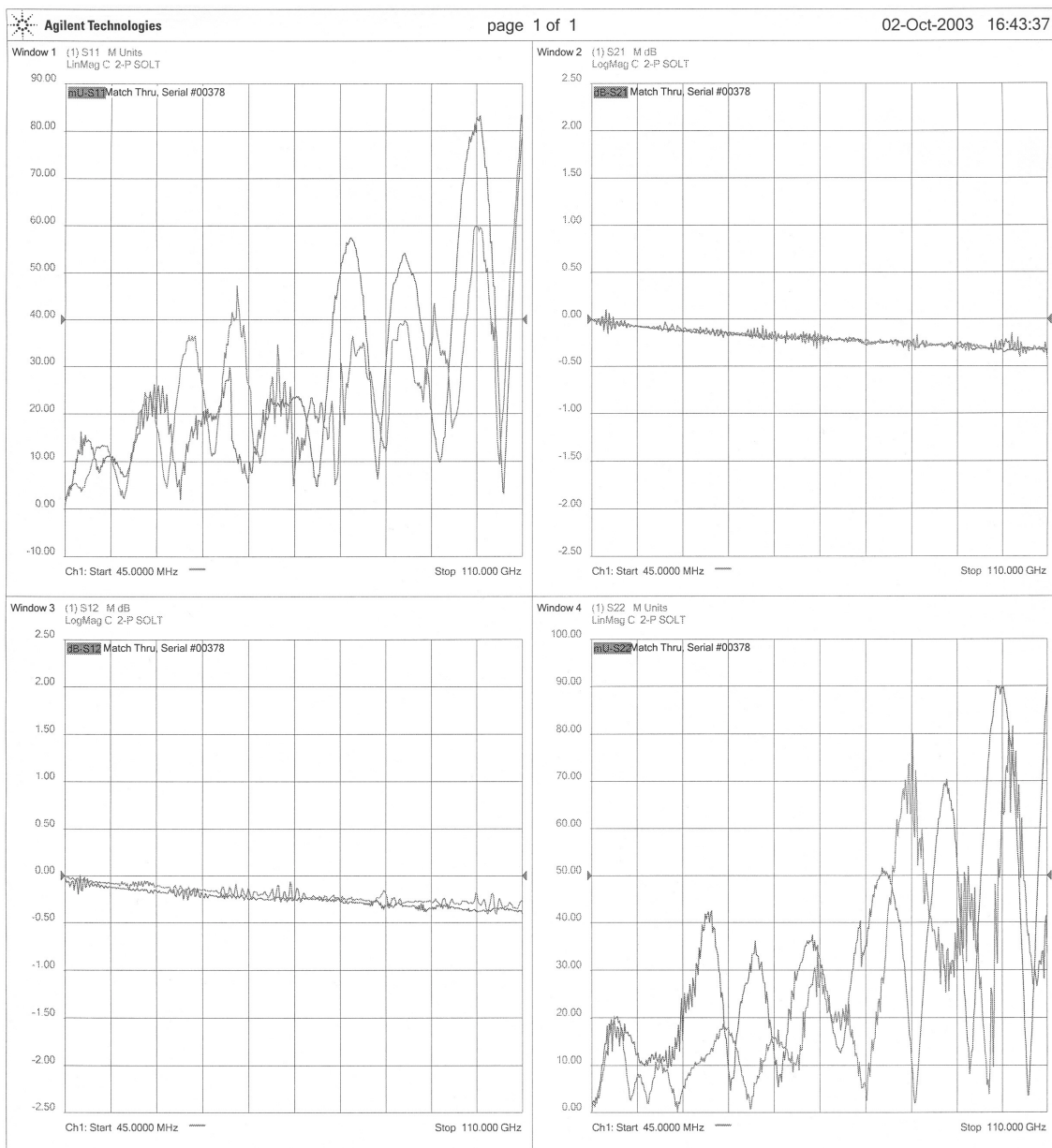

Improving the Verification Results

IMPORTANT Inspect all connections. *Do not* remove the test port cable from the analyzer test port. This *will invalidate* the calibration that you performed earlier.

1. Disconnect and clean the device that failed the verification measurement.
2. Reconnect the device making sure that all connections are torqued to the proper specifications.
3. Measure the device again.
4. If the device still fails the verification measurement, check the measurement calibration by viewing the error terms as described in the PNA Series Network Analyzer embedded help system, “*Monitoring Error Terms Using Cal Set Viewer*”. It will be necessary to re-calibrate if there is a problem with the calibration. The system will not verify correctly with a bad calibration.

2 Safety and Regulatory Information

Information in This Chapter

This chapter provides safety information that will help protect you and your network analyzer. It also contains information that is required by various government regulatory agencies.

Chapter Two at-a-Glance

- Safety Symbols
- General Safety Considerations
- Electrostatic Discharge Protection
- Regulatory Information
- Maintenance
- Replaceable Parts
- Agilent Support, Services, and Assistance

Safety Symbols

The following safety symbols are used throughout this manual. Familiarize yourself with each of the symbols and its meaning before operating this instrument.

CAUTION Caution denotes a hazard. It calls attention to a procedure that, if not correctly performed or adhered to, could result in damage to or destruction of the instrument. Do not proceed beyond a caution note until the indicated conditions are fully understood and met.

WARNING Warning denotes a hazard. It calls attention to a procedure which, if not correctly performed or adhered to, could result in injury or loss of life. Do not proceed beyond a warning note until the indicated conditions are fully understood and met.

General Safety Considerations

Safety Earth Ground

WARNING This is a Safety Class I product (provided with a protective earthing ground incorporated in the power cord). The mains plug shall only be inserted in a socket outlet provided with a protective earth contact. Any interruption of the protective conductor, inside or outside of the instrument, will make the instrument dangerous. Intentional interruption is prohibited.

Before Applying Power

CAUTION This product is designed for use in Installation Category II and Pollution Degree 2 per IEC 1010 and 664 respectively.

CAUTION Make sure that the analyzer line voltage selector switch is set to the voltage of the power supply and the correct fuse is installed.

CAUTION Always use the three-prong AC power cord supplied with this product. Failure to ensure adequate grounding by not using this cord may cause product damage.

CAUTION If this product is to be energized via an autotransformer make sure the common terminal is connected to the neutral (grounded side of the mains supply).

Servicing

WARNING These servicing instructions are for use by qualified personnel only. To avoid electrical shock, do not perform any servicing unless you are qualified to do so.

WARNING The opening of covers or removal of parts may expose dangerous voltages. Disconnect the instrument from all voltage sources while it is opened.

WARNING Danger of explosion if battery is incorrectly replaced. Replace only with the same or equivalent type recommended. Discard used batteries according to manufacturer's instructions.

WARNING Procedures described in this document may be performed with power supplied to the product while protective covers are removed. Energy available at many points may, if contacted, result in personal injury.

WARNING The power cord is connected to internal capacitors that may remain live for 10 seconds after disconnecting the plug from its power supply.

WARNING For continued protection against fire hazard, replace line fuse only with same type and rating. The use of other fuses or material is prohibited.

WARNING The detachable power cord is the instrument disconnecting device. It disconnects the mains circuits from the mains supply before other parts of the instrument. The front panel switch is only a standby switch and is not a LINE switch (disconnecting device).

Electrostatic Discharge Protection

Protection against electrostatic discharge (ESD) is essential while removing assemblies from or connecting cables to the network analyzer. Static electricity can build up on your body and can easily damage sensitive internal circuit elements when discharged. Static discharges too small to be felt can cause permanent damage. To prevent damage to the instrument:

- *always* have a grounded, conductive table mat in front of your test equipment.
- *always* wear a grounded wrist strap, connected to a grounded conductive table mat, having a 1 M Ω resistor in series with it, when handling components and assemblies or when making connections.
- *always* wear a heel strap when working in an area with a conductive floor. If you are uncertain about the conductivity of your floor, wear a heel strap.
- *always* ground yourself before you clean, inspect, or make a connection to a static-sensitive device or test port. You can, for example, grasp the grounded outer shell of the test port or cable connector briefly.
- *always* ground the center conductor of a test cable before making a connection to the analyzer test port or other static-sensitive device. This can be done as follows:
 1. Connect a short (from your calibration kit) to one end of the cable to short the center conductor to the outer conductor.
 2. While wearing a grounded wrist strap, grasp the outer shell of the cable connector.
 3. Connect the other end of the cable to the test port and remove the short from the cable.

Figure 2-1 shows a typical ESD protection setup using a grounded mat and wrist strap.

Figure 2-1 ESD Protection Setup

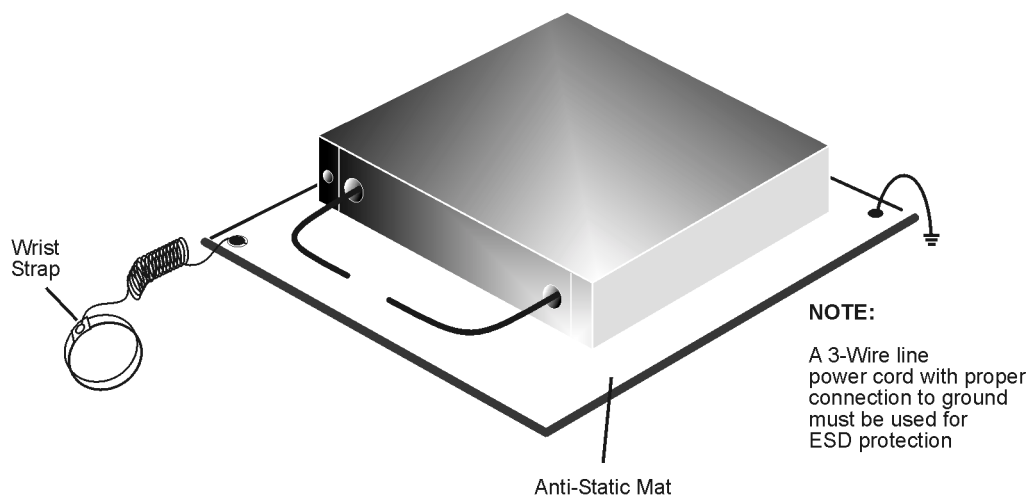

ku310b

Regulatory Information

This section contains information that is required by various government regulatory agencies.

Instrument Markings



The instruction documentation symbol. The product is marked with this symbol when it is necessary for the user to refer to the instructions in the documentation.



The CE mark is a registered trademark of the European Community. (If accompanied by a year, it is when the design was proven.)



The CSA mark is a registered trademark of the Canadian Standards Association.

ICES/NMB-001

This is a marking to indicate product compliance with the Canadian Interference-Causing Equipment Standard (ICES-001).

ISM1-A

This is a symbol of an Industrial Scientific and Medical Group 1 Class A product.





This is a required mark signifying compliance with an EMC requirement. The C-Tick mark is a registered trademark of the Australian Spectrum Management Agency.

Lithium Battery Disposal

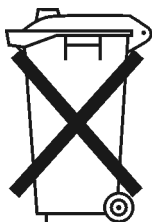
If the battery on the A15 CPU board assembly needs to be disposed of, dispose of it in accordance with your country's requirements. If required, you may return the battery to Agilent Technologies for disposal. Refer to for assistance refer to "Contacting Agilent" on page 2-13.



DO NOT THROW BATTERIES AWAY BUT
COLLECT AS SMALL CHEMICAL WASTE.

 Agilent Technologies	DECLARATION OF CONFORMITY According to ISO/IEC Guide 22 and CEN/CENELEC EN 45014	
---	--	---

Manufacturer's Name: Agilent Technologies, Inc.
Manufacturer's Address: 1400 Fountaingrove Parkway
Supplier's Address: Santa Rosa, California 95403-1799
 USA

Declares under sole responsibility that the product as originally delivered

Product Name: Millimeter-Wave Vector Network Analyzer System
Model Number: N5250A, N5260A
Product Options: This declaration covers all options of the above product(s)

complies with the essential requirements of the following applicable European Directives, and carries the CE marking accordingly:

- The Low Voltage Directive 73/23/EEC, amended by 93/68/EEC
- The EMC Directive 89/336/EEC, amended by 93/68/EEC

and conforms with the following product standards:

EMC	Standard	Limit
	IEC 61326:1997+A1:1998+A2:2000 / EN 61326:1997+A1:1998+A2:2001	
	Reference standards	
	CISPR 11:1997+A1:1999+A2:2002 / EN 55011:1998+A1:1999+A2:2002	Group 1 Class A
	IEC 61000-4-2:1995+A1:1998 / EN 61000-4-2:1995	4 kV CD, 8 kV AD
	IEC 61000-4-3:1995 / EN 61000-4-3:1995	3 V/m, 80-1000 MHz
	IEC 61000-4-4:1995 / EN 61000-4-4:1995	0.5 kV signal lines, 1 kV power lines
	IEC 61000-4-5:1995 / EN 61000-4-5:1995	0.5 kV line-line, 1 kV line-ground
	IEC 61000-4-6:1996 / EN 61000-4-6:1996	3 V, 0.15-80 MHz
	IEC 61000-4-11:1994 / EN 61000-4-11:1994	1 cycle, 100%
	Canada: ICES-001:1998	
	Australia/New Zealand: AS/NZS 2064.1	

The product was tested in a typical configuration with Agilent Technologies test systems.

Safety
 IEC 61010-1:2001 / EN 61010-1:2001
 Canada: CSA C22.2 No. 1010.1:1992
 USA: UL 61010B-1: 2003

Supplementary Information:
 None.

This DoC applies to above-listed products placed on the EU market after:

10 October, 2003

 Date

Paul Forrest
Quality Engineering Manager

For further information, please contact your local Agilent Technologies sales office, agent or distributor, or Agilent Technologies Deutschland GmbH, Herrenberger Straße 130, D 71034 Böblingen, Germany.

Compliance with Canadian EMC Requirements

This ISM device complies with Canadian ICES-001.
Cet appareil ISM est conforme a la norme NMB du Canada.

Compliance with German FTZ Emissions Requirements

This network analyzer complies with German FTZ 526/527 Radiated Emissions and Conducted Emission requirements.

Compliance with German Noise Requirements

This is to declare that this instrument is in conformance with the German Regulation on Noise Declaration for Machines (Laermangabe nach der Maschinenlaermrerordnung-3. GSGV Deutschland).

Acoustic Noise Emission/Geraeuschemission	
LpA<70 dB	Lpa<70 dB
Operator Position	am Arbeitsplatz
Normal Operation	normaler Betrieb
per ISO 7779	nach DIN 45635 t. 19

Maintenance

WARNING **To prevent electrical shock, disconnect the analyzer from the mains source before cleaning. Use a dry cloth or one slightly dampened with water to clean the external case parts. Do not attempt to clean internally.**

Physical Maintenance

Clean the cabinet, including the front panel, using a dry or slightly damp cloth only.

Electrical Maintenance

Refer to “Agilent Support, Services, and Assistance” on page 2-12.

Replaceable Parts

NOTE Special options are built to order, so long lead times may be encountered when ordering replacement parts.

Table 2-1 Replaceable Parts List

Agilent Part Number	Description
Exchange Assemblies:	
N5260-69004	67 GHz to 110 GHz waveguide T/R module, right (rebuilt/exchange)
N5260-69003	67 GHz to 110 GHz waveguide T/R module with attenuator, left (rebuilt/exchange)
System Rear Cables:	
8120-1839	Millimeter head controller IF signal cable (BNC, rear)
08503-60051	Millimeter head controller test set interface cable (rear)
5061-9038	Millimeter head controller RF and LO SMA cable (rear)
System Front Cables:	
8121-1221	Millimeter head controller RF and LO 3.5 mm cable (front)
85105-60033	Millimeter head controller IF signal cable (SMA, front)
85105-60030	Millimeter head controller bias cable (front)
8121-1233	PNA front panel access port RF 1.85 mm (m)-(m) cable
N5260-60009	PNA front panel test port RF 1.85 mm (f)-(m) cable
1250-2604	SMA right angle adapter (not required, use if needed with 8121-1221)
Combiner Assembly Parts:	
N5260-60005	WR-10 2 inch long waveguide section
1390-0765	4-40 captive screw (waveguide flange)
2190-0556	4-40 split-lock washer (waveguide flange)
N5260-00007	Bracket-right combiner assembly
N5260-00008	Bracket-left combiner assembly
0515-0372	M3.0 x 8 mm screw (bracket)
85104-60061	1.0 mm test port connector
2190-0104	Washer (for 1 mm connector)

Table 2-1 Replaceable Parts List

2950-0132	Nut (for 1 mm connector)
Accessories:	
N5250-90001	N5250A installation guide
9211-8177	Shipping container for millimeter-wave test heads and subcomponents (combiner assembly and/or waveguide T/R module)
Documentation:	
E8356-10001 Includes:	PNA Series Network Analyzer CD-ROM
E8356-90001	Installation and Quick Start Guide (PDF format)
E8361-90001	Service Guide (PDF format)
	Embedded Help (PDF format)
	Embedded Help program to run on a PC

Agilent Support, Services, and Assistance

Information on the following topics is included in this section.

- “Contacting Agilent”
- “Service and Support Options”
- “Shipping Your Analyzer to Agilent for Service or Repair”

Contacting Agilent

By internet, phone, or fax, get assistance with all your test and measurement needs.

Online assistance: www.agilent.com/find/assist			
Americas			
Brazil (tel) (+55) 11 4197 3600 (fax) (+55) 11 4197 3800	Canada (tel) 877 894 4414 (fax) (+1) 905 282-6495	Mexico (tel) (+52) 55 5081 9469 (alt) 01800 5064 800 (fax) (+52) 55 5081 9467	United States (tel) 800 829 4444 (alt) (+1) 303 662 3998 (fax) 800 829 4433
Asia Pacific and Japan			
Australia (tel) 1800 629 485 (alt) 1800 143 243 (fax) 1800 142 134	China (tel) 800 810 0189 (alt) (+86) 10800 650 0021 (fax) 800 820 2816	Hong Kong (tel) 800 930 871 (alt) (+852) 3197 7889 (fax) (+852) 2 506 9233	India (tel) 1600 112 929 (fax) 000800 650 1101
Japan (tel) 0120 421 345 (alt) (+81) 426 56 7832 (fax) 0120 421 678	Malaysia (tel) 1800 888 848 (alt) 1800 828 848 (fax) 1800 801 664	Singapore (tel) 1800 375 8100 (alt) (+65) 6 375 8100 (fax) (+65) 6836 0252	South Korea (tel) 080 769 0800 (alt) (+82) 2 2004 5004 (fax) (+82) 2 2004 5115
Taiwan (tel) 0800 047 866 (alt) 00801 651 317 (fax) 0800 286 331	Thailand (tel) 1800 226 008 (alt) (+66) 2 268 1345 (fax) (+66) 2 661 3714		
Europe			
Austria (tel) 0820 87 44 11* (fax) 0820 87 44 22	Belgium (tel) (+32) (0)2 404 9340 (alt) (+32) (0)2 404 9000 (fax) (+32) (0)2 404 9395	Denmark (tel) (+45) 7013 1515 (alt) (+45) 7013 7313 (fax) (+45) 7013 1555	Finland (tel) (+358) 10 855 2100 (fax) (+358) 10 855 2923
France (tel) 0825 010 700* (alt) (+33) (0)1 6453 5623 (fax) 0825 010 701*	Germany (tel) 01805 24 6333* (alt) 01805 24 6330* (fax) 01805 24 6336*	Ireland (tel) (+353) (0)1 890 924 204 (alt) (+353) (0)1 890 924 206 (fax) (+353) (0)1 890 924 024	Israel (tel) (+972) 3 9288 500 (fax) (+972) 3 9288 501
Italy (tel) (+39) (0)2 9260 8484 (fax) (+39) (0)2 9544 1175	Luxemburg (tel) (+32) (0)2 404 9340 (alt) (+32) (0)2 404 9000 (fax) (+32) (0)2 404 9395	Netherlands (tel) (+31) (0)20 547 2111 (alt) (+31) (0)20 547 2000 (fax) (+31) (0)20 547 2190	Russia (tel) (+7) 095 797 3963 (alt) (+7) 095 797 3900 (fax) (+7) 095 797 3901
Spain (tel) (+34) 91 631 3300 (alt) (+34) 91 631 3000 (fax) (+34) 91 631 3301	Sweden (tel) 0200 88 22 55* (alt) (+46) (0)8 5064 8686 (fax) 020 120 2266*	Switzerland (French) (tel) 0800 80 5353 opt. 2* (alt) (+33) (0)1 6453 5623 (fax) (+41) (0)22 567 5313	Switzerland (German) (tel) 0800 80 5353 opt. 1* (alt) (+49) (0)7031 464 6333 (fax) (+41) (0)1 272 7373
Switzerland (Italian) (tel) 0800 80 5353 opt. 3* (alt) (+39) (0)2 9260 8484 (fax) (+41) (0)22 567 5314	United Kingdom (tel) (+44) (0)7004 666666 (alt) (+44) (0)7004 123123 (fax) (+44) (0)7004 444555		
(tel) = primary telephone number; (alt) = alternate telephone number; (fax) = FAX number; * = in country number			

Service and Support Options

The N5250A system has a *one-year on-site service warranty* which covers troubleshooting the system to an individual instrument or cable.

NOTE There are many other repair and calibration options available from the Agilent Technologies support organization. These options cover a range of service agreements with varying response times. Contact Agilent for additional information on available service agreements for this product. Refer to “Contacting Agilent” on page 2-13.

Shipping Your Analyzer to Agilent for Service or Repair

IMPORTANT Agilent Technologies reserves the right to reformat or replace the internal hard disk drive in your analyzer as part of its repair. This will erase all user information stored on the hard disk. It is imperative, therefore, that you make a backup copy of your critical test data located on the analyzer’s hard disk before shipping it to Agilent for repair.

If you wish to send your network analyzer to Agilent Technologies for service or repair:

- Include a complete description of the service requested or of the failure and a description of any failed test and any error message.
- Ship the analyzer using the original or comparable antistatic packaging materials.
- Contact Agilent for instructions on where to ship your analyzer. Refer to “Contacting Agilent” on page 2-13.